

Specifications

Model Number: C019

Shaft: 3" type 304 stainless steel pipe with a machined type 304 base plate.

Joint: Precision machined Delrin® flow control joint factory adjustable for 45°-360° directional flow.

Body: Type 304 stainless steel manifold housed in a vandal-resistant polymer body.

Anchor Base: Type 304 stainless steel pipe with top plate machined to mate with shaft base plate with grounding connection, base plate, and 2" FPT inlet. Supplied with four 3/8" x 12" x 2" anchor bolts with two leveling nuts and washers per bolt, and wood template.

Gasket: 70 durometer EPDM o-ring.

Fasteners: Tamper-resistant 18/8 stainless steel.

Finish: Textured elastomeric urethane with a UV and chlorine resistant sealer coat.

Nozzle: Machined PVC spray nozzle.

Color Cast: A rigid urethane polymer intended for translucent color accents with resistance to chlorine and UV.

Nozzle: Machined brass foam nozzle.

Options:

- Water Conserving Nozzle.** Add catalog number suffix, -C

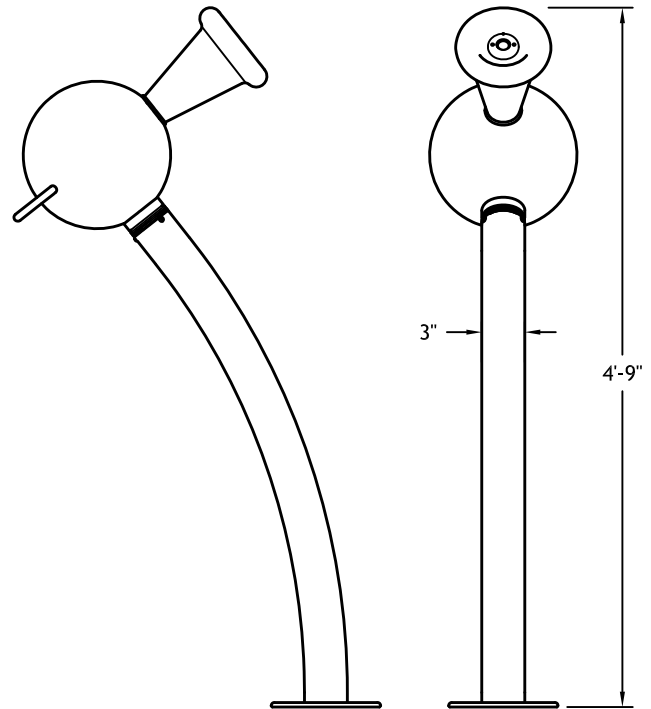
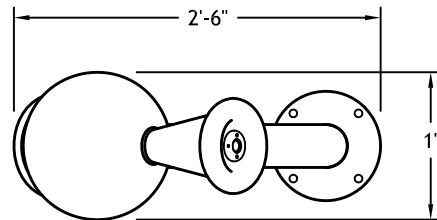

Anchor Base

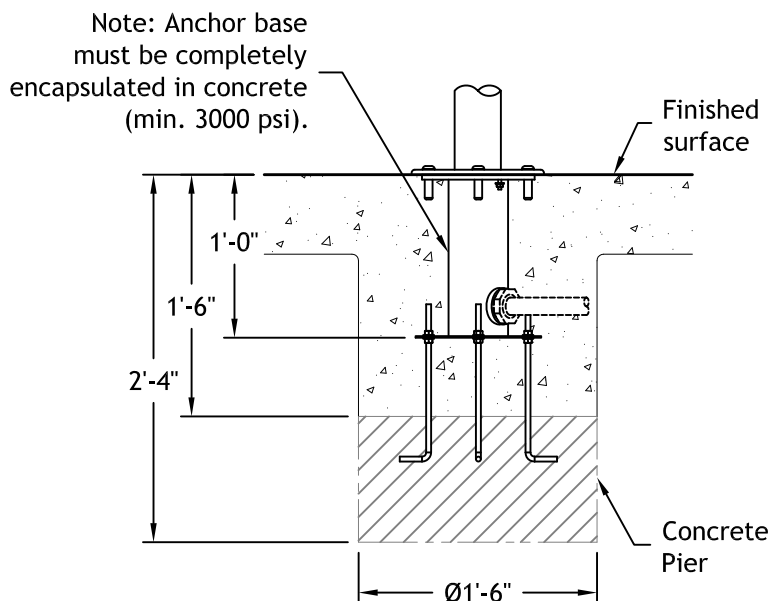

Splash Zone

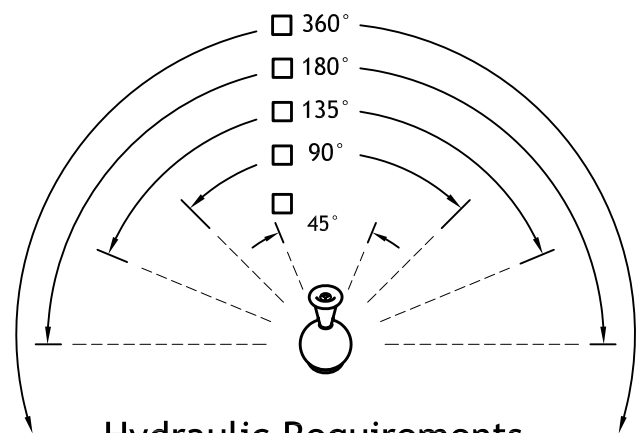

Hydraulic Requirements

<input type="checkbox"/> C019	Throw	GPM	psi
	20	18	20
<input type="checkbox"/> *C019C - Water Conserving Version	Throw	*CGPM	*Cpsi
	20	12	13

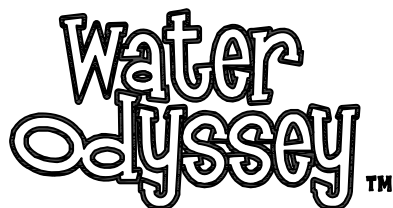

C019 Snoot Shooter™